

MANUAL

FOR SAFETECH FENCE

EUROPEAN PATENT 3670742

Date of issue: July 25 2024
Versie: 1.6



1. APPLICATION

1.1 Details

- The minimum composition and length of an 'Safetech Fence' safety barrier includes two stanchions and two barriers (top and bottom) and has to be used with a spacing of approximately 3 metres between stanchions). Each stanchion has a fixed and adjustable part.
- **No** track ballast needs to be removed beforehand installation.
- Can be used at least on rail types NP46, S49, UIC 54, S54, UIC 60, in combination with the use of a sleeper screw and different kinds of rail clips / rail fasteners.
- The foot clamp of the Safetech Fence only requires a space of 25 mm under the rail foot. This makes the Safetech Fence also useable on the High-speed rail
- The Safetech Fence is adjustable in 0.1-metre stages between 1.95 - 2.55 metres.

- In case of emergency, the barriers can be removed to create a free passage. To do this, first loosen the wing screws (which hold the barriers in place).
- When using the Safetech Fence at 1.95 m, the slide support must be moved as far as possible in the direction of the foot clamp. Then, after unlocking the counter nut, the spacer bolt must be screwed in as far as possible and locked again with the counter nut.

1.2 Preparation

- During work preparation, determine the correct distance between the fixed barrier and the centre of the track. Furthermore, all safety precautions and all rules and standards applicable to safety on the track must be observed.



1.3 Points to consider before starting assembly

- Make sure you have the correct parts available.
- Adjust the Safetech Fence to the correct distance (see fig. 1 and 2).

1.4 Adjusting the distance of the Safetech Fence barrier to the track centreline.

Safetech Fence
 Manufacturer: RSC
 Project No. : 1024XXX



1	<input type="radio"/>	2,55 mtr.
2	<input type="radio"/>	2,45 mtr.
3	<input type="radio"/>	2,35 mtr.
4	<input type="radio"/>	2,25 mtr.
5	<input type="radio"/>	2,15 mtr.
6	<input type="radio"/>	2,05 mtr.
7	<input type="radio"/>	1,95 mtr.

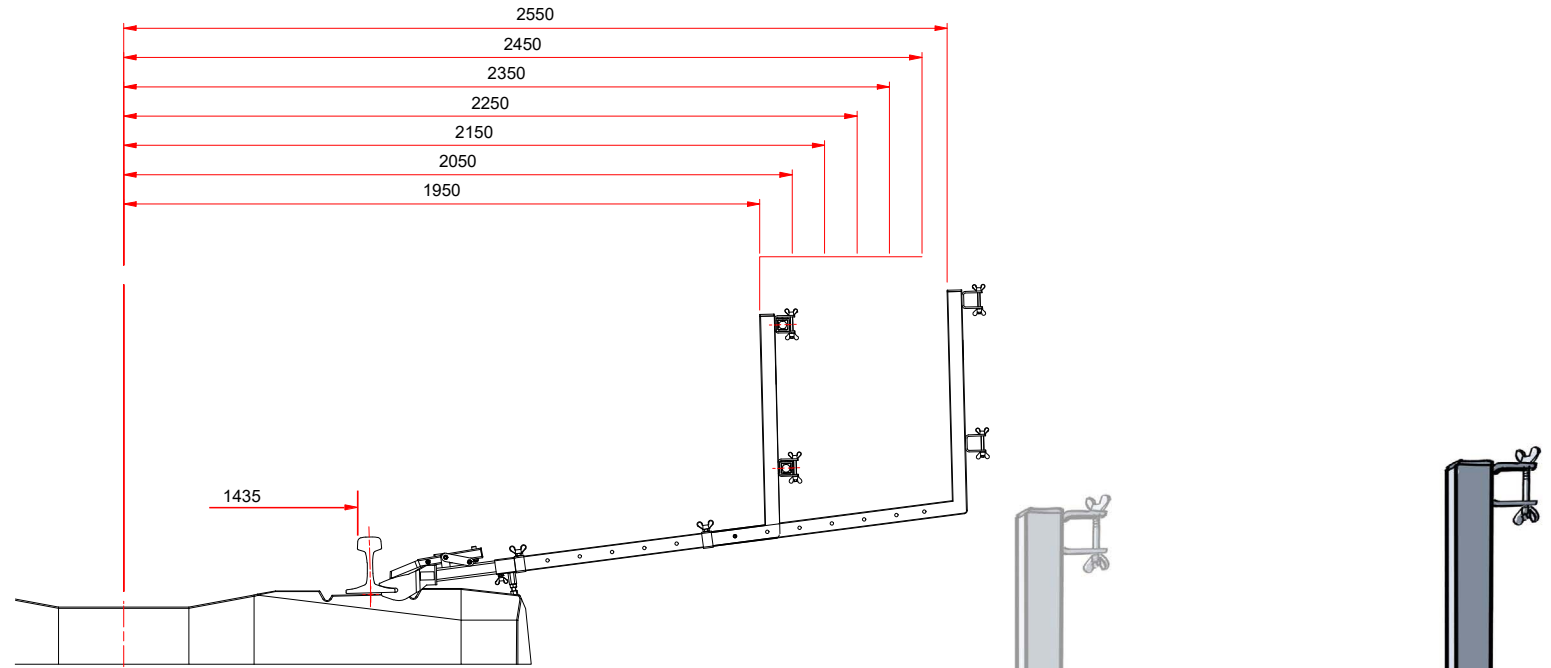

Distance between inside stanchion and centre of the track.

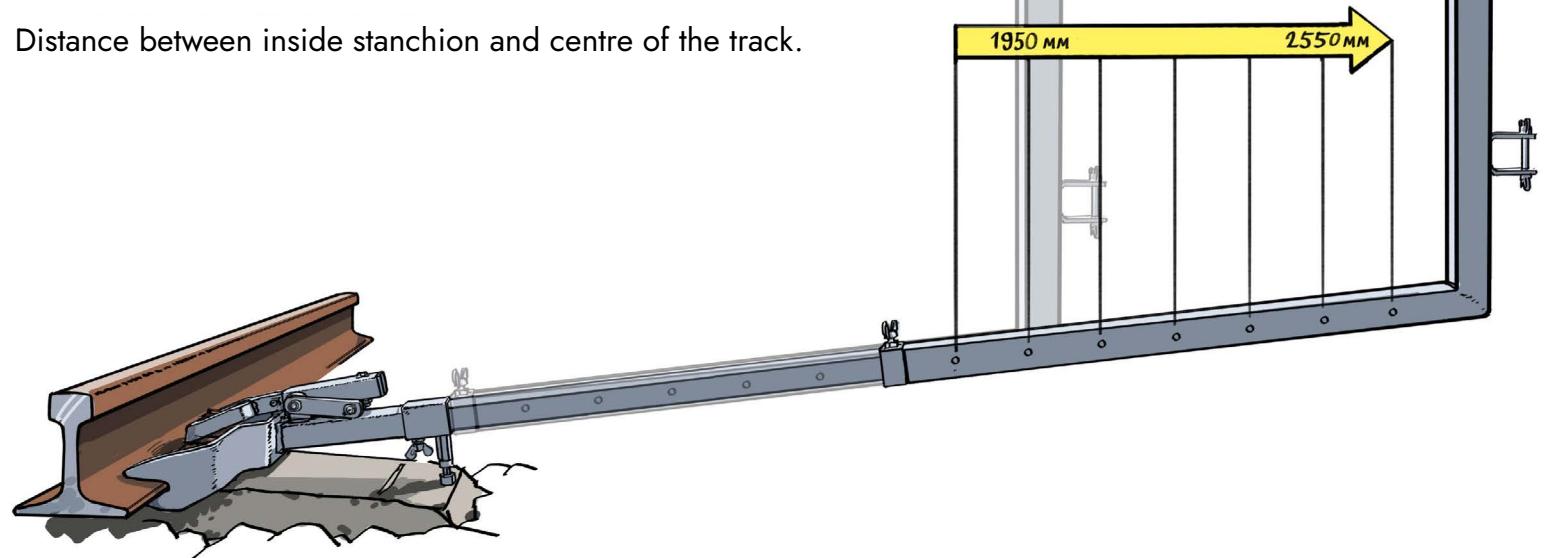

Hole pattern, as seen from the track.

Figure 1

Figure 2

1.5 ASSEMBLY

1.5.1 Initial conditions

→ The assembly job can only be started after receiving the specific assembly and disassembly instructions and thoroughly studying and understanding them.

→ Adjust the stanchion to the correct distance to the centre of the track by setting the connection between the fixed and adjustable stanchion to the correct hole position and secure this setting with the wing screw (see fig. 3).

→ Prepare the material for assembling outside the danger zone.

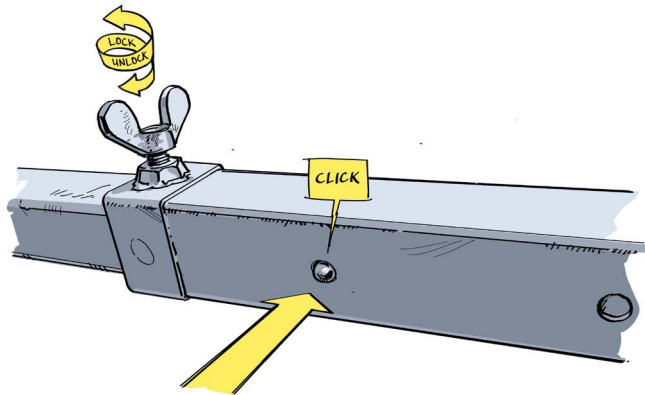

Figure 3

→ Before assembly, ensure that the parts/ components to be assembled are clean, undamaged and ready for operation.

1.5.2 Mounting the adjusted stanchions

→ Assemble the first adjusted stanchion by placing the quick-release fastener over the foot of the rail on the outside of the rail track, where by the mechanism hooks over the rail fastener. The mechanism is hereby in a released state (see fig. 4).

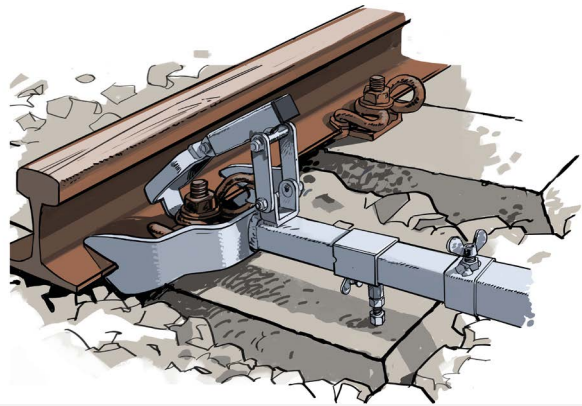

Figure 4

→ Place the lever (assembly tool) over the clamping mechanism and tension the mechanism by moving the lever towards the stanchion (see fig. 5, 6 and 7).

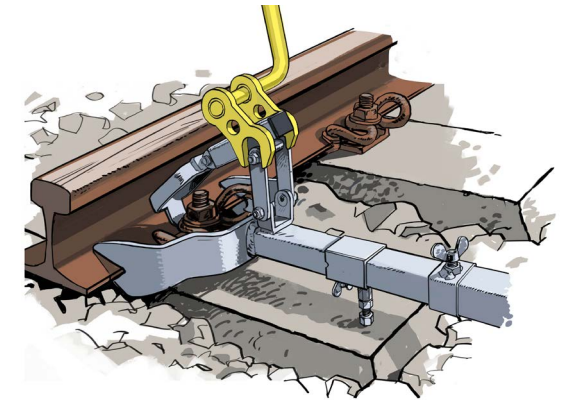

Figure 5

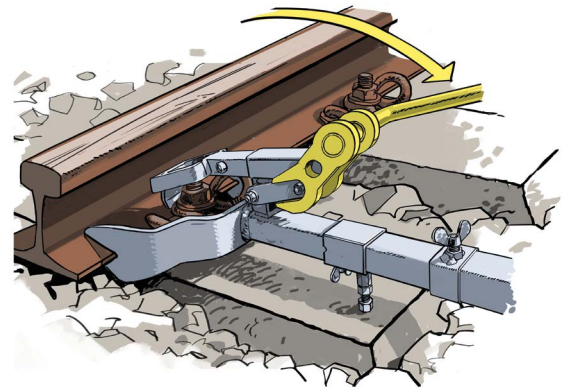

Figure 6

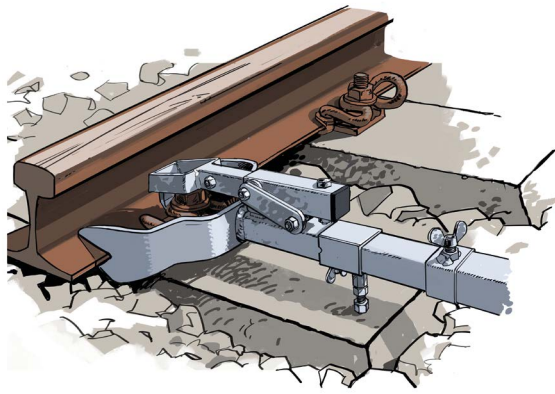

Figure 7

- Check that the clamping mechanism hooks correctly behind the rail clip and that the stanchion has been solidly mounted.
- Remove the lever.
- When using the Safetech Fence the slide support should be pushed as far outward as possible and locked with the wing screw (see fig. 8).

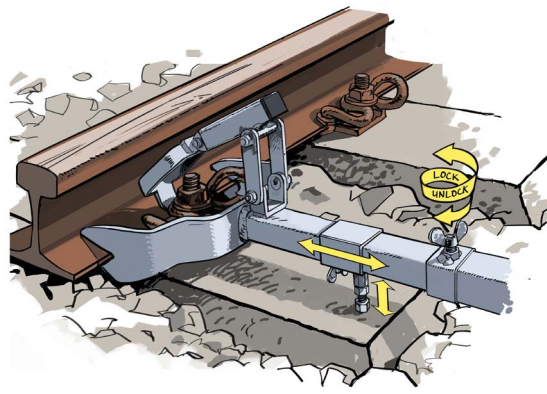

Figure 8

- After unlocking the counter nut, the spacer bolt should be unscrewed until it rests on the sleeper without play. Then tighten the counter nut to lock the spacer bolt (see fig. 8).
- Place the second stanchion at a distance of approx. 2.4 metres. from the first stanchion (see fig.9).

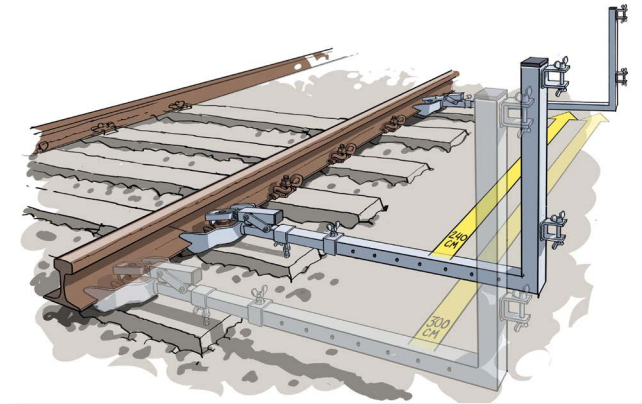

Figure 9

- Always mount all following stanchions at a maximum of 3.0 metres from the previous stanchion (see fig. 9).
- Place the last stanchion at a distance of approx. 2.4 metres distance from the second-to-last stanchion.

1.5.3 Mounting upper barrier

→ Insert the first barrier with the connection element through the upper barrier bracket of the first and second stanchion. The 'open end' must protrude approximately 10 cm. through the second barrier bracket (see figure 10).



Figure 10

→ Insert a securing device (wedge) between the top of the upper barrier and the top of the barrier bracket of the first and second stanchion and hit it until you feel enough resistance (see fig. 11).

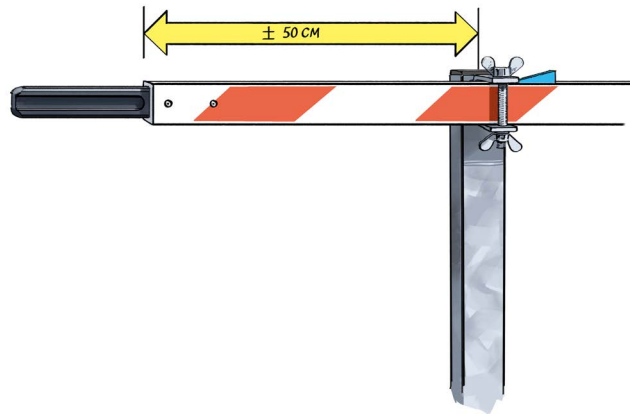

Figure 11

→ Check that the barrier can no longer move in relation to the stanchion.

→ Then assemble the next stanchions by coupling them together (see fig. 12).

→ The last barrier should also be secured with a wedge, as described above.

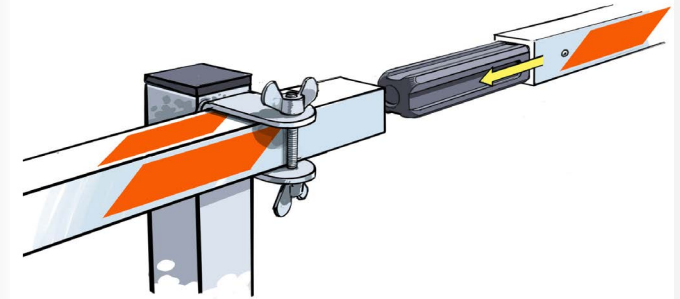

Figure 12

1.5.4 Assembly of the lower barrier

→ See assembly of upper barrier (see fig. 13).



Figure 13

1.6 Marking and requirements of horizontal barriers

Figures 11 to 13 show the use of barriers with warning markings. The visible surfaces with red and white stripes fulfil the requirements if:

- The width ratio of the stripes is 1:1.
- The stripes shall be applied at an angle of 45°.

Alternatively, this requirement is also considered to be fulfilled if at least the colour sequence of the upper- and lower barrier differs per section.

If the last option is chosen, the Safetech Fence must be constructed according to the following principle. (see fig. 14).

The technical and mechanical characteristics of these coloured barriers are the same as the white barrier with warning markings.

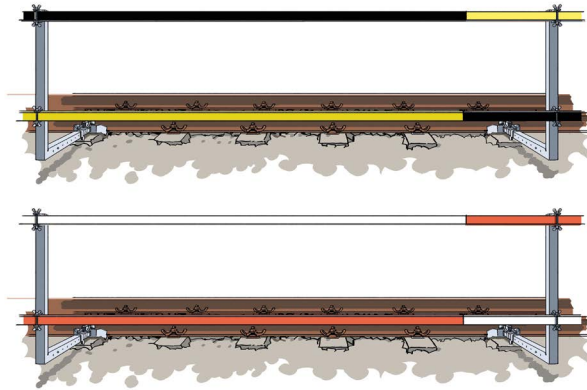

Figure 14

1.7 Use

- Check the condition of the Safetech Fence on a regular base.

1.8 Disassembly

- 1 Always place the dismantled parts outside the danger zone.
- 2 Remove the lower barrier after you have removed the wedge (securing device).
- 3 Then remove the upper barrier after you have removed the wedge (securing device).
- 4 Remove the stanchions after releasing the clamping mechanism by means of the lever.
- 5 Set the clamping mechanism to the transport position.

2. MAINTENANCE, STORAGE AND TRANSPORT

2.1 Maintenance

All parts must be checked regularly for wear, damage and operation/function. Incomplete and defective parts must be replaced with original spare parts.

2.2 Storage

The product can be stored on specially designed transport frames (see fig. 15 and 16).

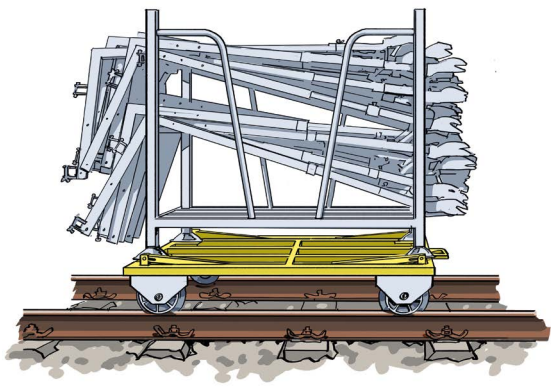

Figure 15

2.3 Transport

The transport frames, which are designed for storage, can be stacked and can be loaded or unloaded with a forklift truck or a truck with loading crane.

2.3.1 Transportbok voor staanders

For storage / transport of at least 50 stanchions. Stackable and fits on specially designed rail trolleys (see fig. 15).

2.3.2 Transport frame for barriers

For storage / transport of at least 200 barriers (see fig. 16).

Stackable and fits also on the rail trolley. Lorries can be interconnected by means of a drawbar.

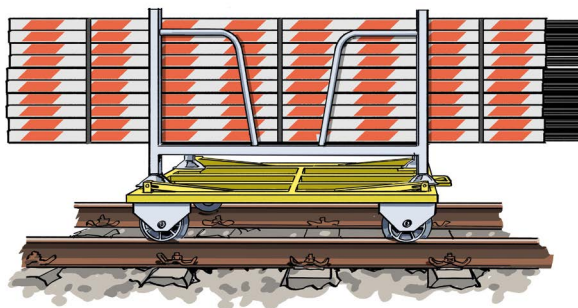
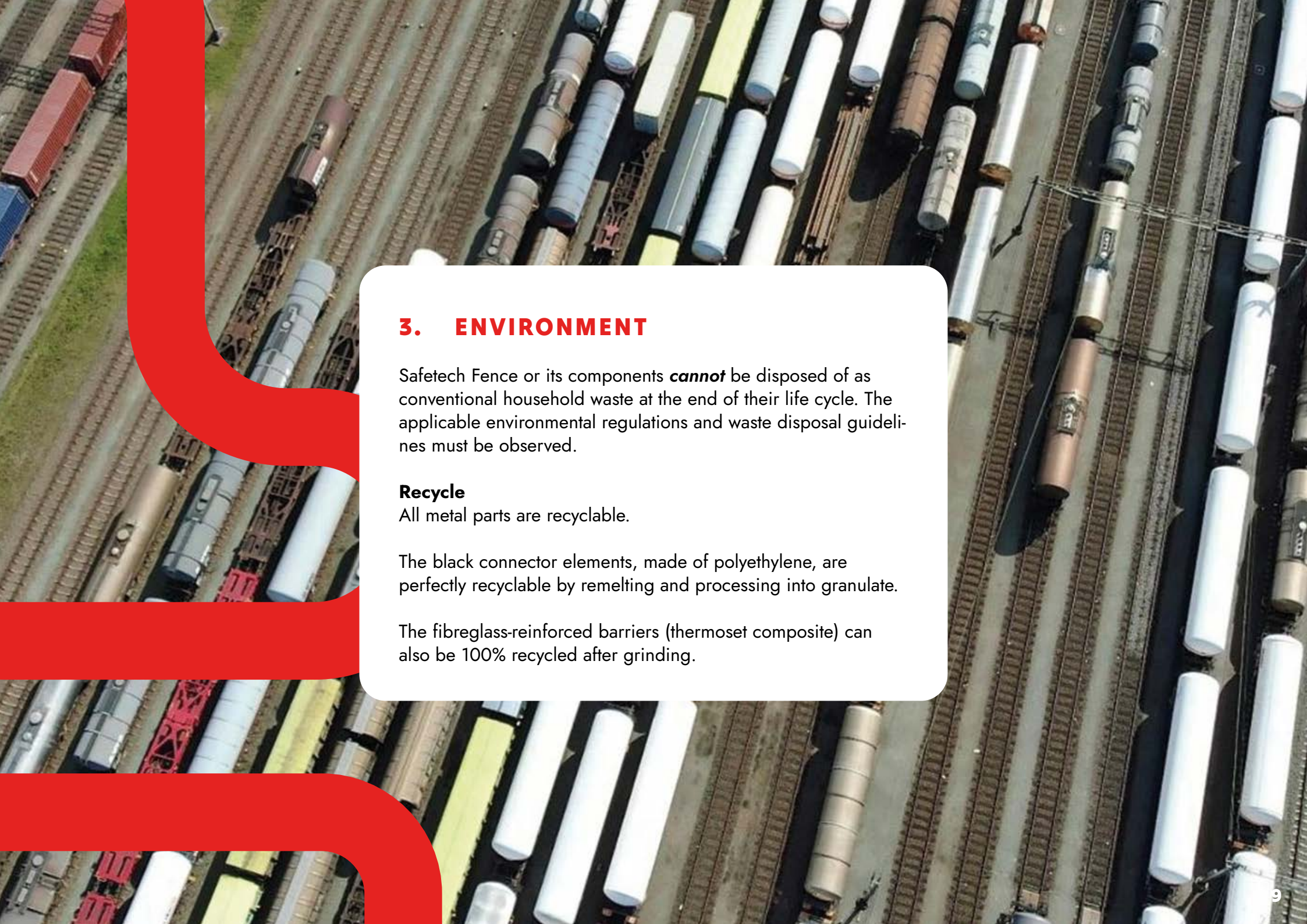

Figure 16



3. ENVIRONMENT

Safetech Fence or its components **cannot** be disposed of as conventional household waste at the end of their life cycle. The applicable environmental regulations and waste disposal guidelines must be observed.

Recycle

All metal parts are recyclable.

The black connector elements, made of polyethylene, are perfectly recyclable by remelting and processing into granulate.

The fibreglass-reinforced barriers (thermoset composite) can also be 100% recycled after grinding.

